

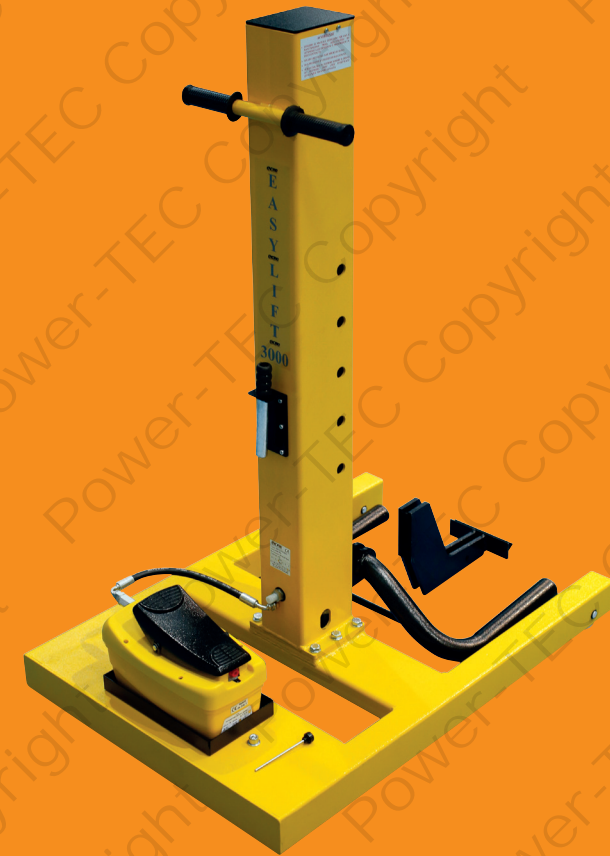

## Easy Lift Hydraulic 3000kg



### Safety Guidelines:

- Locate the vehicle and Easy Lift on a level and solid floor.
- Engine must be switched off.
- Handbrake must be OFF and gearlever in neutral.
- Tyre pressures must be to manufacturers' recommendations.
- If using sill-lifter it must be positioned at forward sill jacking point on a front-engined vehicle. (Refer to manufacturers' handbook.)
- Always support vehicle with axle stand(s). Ensure the vehicle is sitting securely on the support stands before getting under vehicle.
- Do not exceed the weight capacity of the Easy Lift (1500kg).
- Do not use the Easy Lift if damaged.
- Do not allow untrained persons to operate the Easy Lift.

Note: No responsibility is accepted for incorrect use of the Easy Lift.



**Safety First. Be Protected.**

Our products are designed to be used correctly and with care for the purpose for which they are intended. No liability is accepted by the Tool Connection for incorrect use of any of our products, and the Tool Connection cannot be held responsible for any damage to personnel, property or equipment when using the tools. Incorrect use will also invalidate the warranty.

If applicable, the applications database and any instructional information provided has been designed to offer general guidance for a particular tool's use and while all attention is given to the accuracy of the data no project should be attempted without referring first to the manufacturer's technical documentation (workshop or instruction manual) or the use of a recognised authority such as Autodata.

It is our policy to continually improve our products and thus we reserve the right to alter specifications and components without prior notice. It is the responsibility of the user to ensure the suitability of the tools and information prior to their use.

### Guarantee

If this product fails through faulty materials or workmanship, contact our service department direct on: **+44 (0) 1926 818186**. Normal wear and tear are excluded as are consumable items and abuse.

[www.power-tec.co.uk](http://www.power-tec.co.uk)



Distributed by The Tool Connection Ltd

Kington Road, Southam, Warwickshire CV47 0DR  
T +44 (0) 1926 815000 F +44 (0) 1926 815888  
info@toolconnection.co.uk [www.toolconnection.co.uk](http://www.toolconnection.co.uk)



5 018341 924096 >



[www.power-tec.co.uk](http://www.power-tec.co.uk)

## Easy Lift Hydraulic

Ideal for bodyshops, this mobile vehicle lift will raise cars and light commercials to a maximum height of 995mm. No electrical connections are required as the Easy Lift uses a 350bar hydraulic pump powered by the workshop compressed air supply. Can lift via the wheel or the sill. Easily manoeuvred around the workshop.

### Controls:

Fig 1

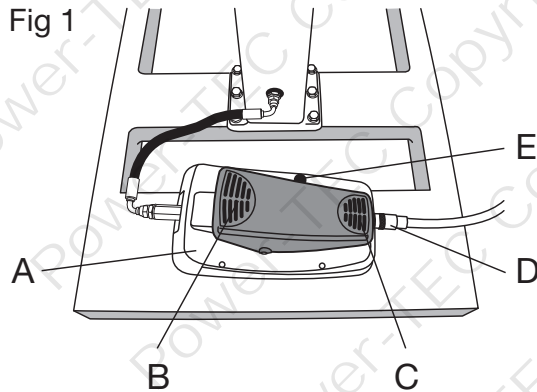

Refer to **Fig. 1**:

- A: Hydraulic pump
- B: **LOWER** pedal
- C: **RAISE** pedal
- D: Compressed air inlet
- E: Oil level dipstick and fill hole

### Specifications:

- Weight: 85kg
- Lifting Capacity: 1500kg (per side: 3000kg max vehicle weight)
- Max Lifting Height: 995mm

### BEFORE YOU START:

- Check vehicle's tyre pressures (on all wheels) and ensure they are to manufacturer's specification.
- Before attempting to lift vehicle, ensure that the handbrake is OFF and the gear lever is in neutral.
- Read these instructions and be aware of how to operate the Easy Lift. Prior to first use refer to **Hydraulic Pump Oil Level** (below) and **Fig. 5**.

## Easy Lift Hydraulic

### Instructions

#### Raising:

1. Move Easy Lift to vehicle using the handlebars.
2. Place in desired position, ie, at the front or rear wheel of vehicle (if using the wheel lifter) or fitted under the forward sill jacking point (if using the sill lifter on a front-engined vehicle).
3. Connect to suitable compressed air supply (dry air, 8–10 bar).
4. To lift the vehicle, press foot pedal **C**.
5. Refer to **Fig. 2**: Once vehicle is at required height, insert safety locking pin into hole immediately below the lifter.
6. Press foot pedal **B** to lower the vehicle slightly so that the weight is taken by the safety locking pin.
7. Once lifted, always additionally support the vehicle with axle stand(s).

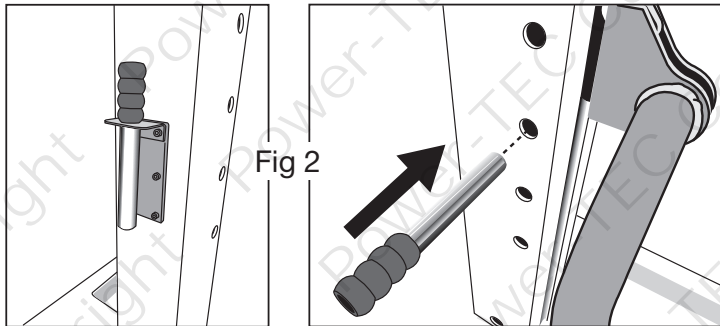

#### Lowering:

1. Lift the vehicle slightly to take the load off the safety locking pin by pressing foot pedal **C**.
2. Remove safety locking pin.
3. Press foot pedal **B** to lower the vehicle.

#### Lifting Attachments:

The Easy Lift is supplied with wheel-lifter and a sill-lifter. (Refer to **Figs. 3 & 4.**)

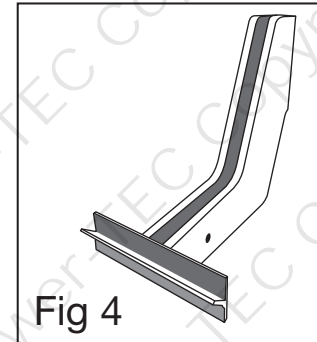

Fig 4

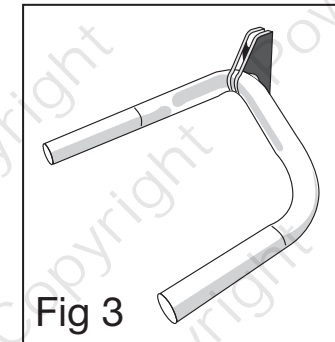

Fig 3

To change lifting attachments, tilt the existing attachment up about 45°, then unhook from lifter attachment point.

**NOTE:** If using sill-lifter, **it must only be fitted to the forward sill jacking point on a front-engined vehicle** (refer to manufacturer's handbook or documentation for correct position of sill jacking points.)

## Easy Lift Hydraulic

### Hydraulic Pump Oil Level:

The Easy Lift hydraulic pump is supplied ready-filled with hydraulic oil. Prior to first use remove the sealing plug from the dipstick hole (**E** on **Fig. 1**) and fit the cap/dipstick assembly. Then connect the hydraulic pipe from the pump to the hydraulic cylinder and ensure the fittings are tight and secure.

Unless the system is leaking, there will be no loss of hydraulic oil in use. To check the oil level, ensure the wheel or sill lifter is at its lowest point (so that there is no hydraulic oil in the lifting cylinder) and use the dipstick (refer to **Fig. 5**). The correct oil level is at the top marking on the dip stick (**F**).

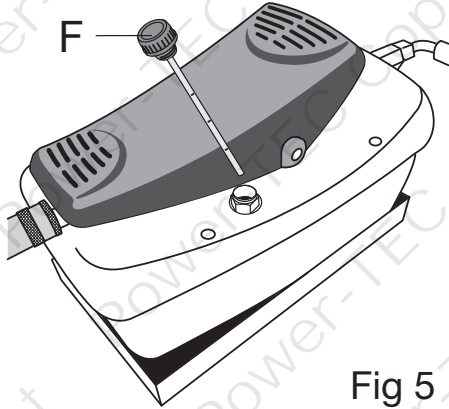

Fig 5

### Why does the vehicle not turn over when lifting it with the Easy Lift?

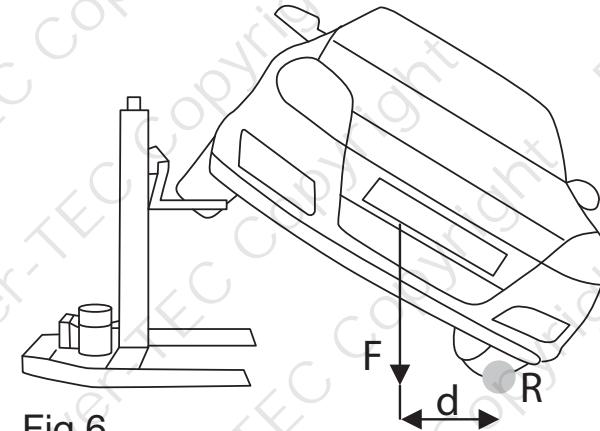

Fig 6

Refer to **Fig. 6**: the vehicle is shown by the force (**F**) representing its weight. The force (**F**) will remain vertical as the vehicle gradually inclines. On the other side is the point of rotation (**R**). While the vehicle is inclining, the distance between (**F**) and (**R**) decreases. Until this distance (**D**) doesn't reach zero or turn negative, the vehicle won't turn over. This will never happen with the Easy Lift.