

- Once camshafts are set correctly, and the retaining frame has been placed upon the camshafts, lock in position with the camshaft retaining clamp (2 in Fig 8).
- Refer to manufacturer's documentation for the correct sequence of tightening the retaining frame bolts and nuts and the manufacturer's specified torque figure.

Our products are designed to be used correctly and with care for the purpose for which they are intended. No liability is accepted by the Tool Connection for incorrect use of any of our products, and the Tool Connection cannot be held responsible for any damage to personnel, property or equipment when using the tools. Incorrect use will also invalidate the warranty.

If applicable, the applications database and any instructional information provided has been designed to offer general guidance for a particular tool's use and while all attention is given to the accuracy of the data no project should be attempted without referring first to the manufacturer's technical documentation (workshop or instruction manual) or the use of a recognised authority such as Autodata.

It is our policy to continually improve our products and thus we reserve the right to alter specifications and components without prior notice. It is the responsibility of the user to ensure the suitability of the tools and information prior to their use.



Safety First. Be Protected.

Guarantee

If this product fails through faulty materials or workmanship, contact our service department direct on: **+44 (0) 1926 818186**. Normal wear and tear are excluded as are consumable items and abuse.



Distributed by The Tool Connection Ltd

Kineton Road, Southam, Warwickshire CV47 0DR
 T +44 (0) 1926 815000 F +44 (0) 1926 815888
 info@toolconnection.co.uk www.toolconnection.co.uk



LASER[®]

6253

Diesel Camshaft/Head Rebuild Kit Volkswagen Audi Group, Porsche

Instructions

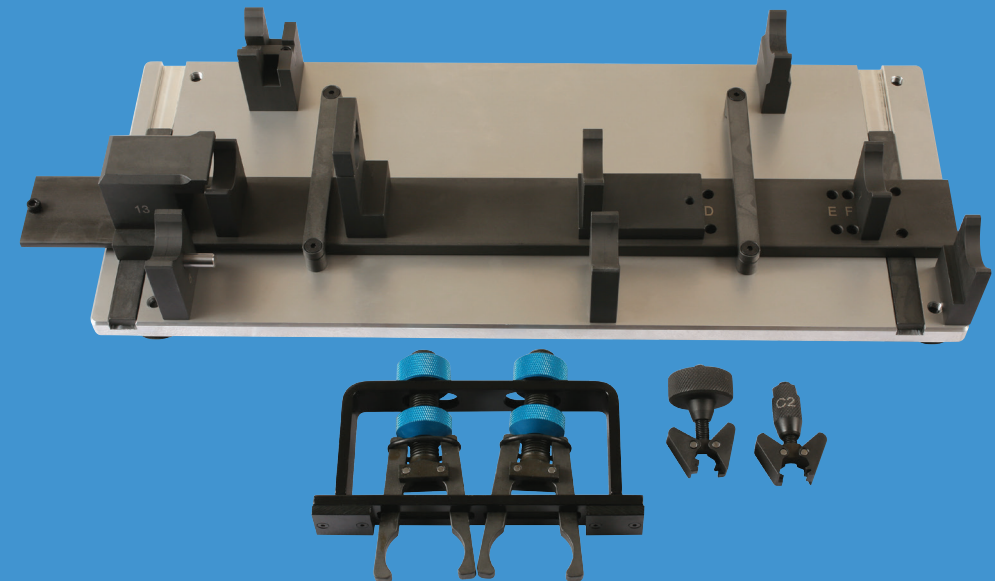

Manufacturer	Year	Description	Engine	
Audi	2003-2015	Common Rail Diesel Engines TDI CR	1.2,	ASB, ASE, BKN, BKS, BMK, BNG, BPP, BSG, BTR, BUG, BUN, BVN, CAAA, CAAB, CAAC, CAAD, CAAE, CAGA, CAGB, CAGC, CAHA, CAHB, CAMA, CAMB, CANA, CANB, CANC, CAND, CAPA, CARA, CASA, CASB, CASC, CASD, CATA, CAYA, CAYB, CAYC, CAYD, CAYE, CBAA, CBAB, CBAC, CBBA, CBBB, CBDA, CBDB, CBDC, CCFA, CCFC, CCHA, CCHB, CCLA, CCMA, CCWA, CCWB, CDBA, CDCA, CDSB, CDTA, CDTB, CDUC, CDUD, CDYA, CDYB, CDYC, CEGA, CEXA, CFCA, CFFA, CFFB, CFFD, CFFE, CFGB, CFGC, CFGD, CFHA, CFHB, CFHC, CFHD, CFHE, CFHF, CFJA, CFWA, CGKA, CGKB, CGLA, CGLB, CGLC, CGLD, CGLE, CGQB, CJAA, CJCA, CJCB, CJCC, CJCD, CJGA, CJGC, CJGD, CJMA, CKDA, CKTB, CKTC, CKUB, CKUC, CKVB, CKVC, CLAA, CLAB, CLCA, CLCB, CLJA, CLLA, CLNA, CLZB, CMEA, CMFA, CMFB, CMGB, CMHA, CNEA, CNFA, CNRB, CRCA, CSHA, M05/9D (CAS), M05/9E, M05/9E (CRCA), M05/9E (CRCB)
Porsche			1.6,	
			2.0,	
			2.7,	
			3.0,	
Seat		4.0,		
		4.2,		
Skoda				
Volkswagen				

Please refer to website for a full application list.

Camshaft/Head Rebuild Kit - Instructions

This tool set is equivalent to OEM tooling and is specifically designed to allow the camshafts to be refitted into the cylinder head in their correct timed position. This is necessary because the cylinder heads are designed with a camshaft retaining frame that splits from the cylinder head along the centre line of the cam bearing caps. When refitting the existing or new camshafts they need to be assembled correctly in the retaining frame and then clamped in place while assembling to the cylinder head. The camshafts must be installed with the camshaft fitting jig, otherwise the camshaft bearings in the retaining frame will be destroyed and the cylinder head must be replaced. The set comprises a jig, plus various camshaft support fixtures, locking devices and gear tooth alignment clamps.

Due to the large number of engine applications that this set covers, the manufacturer's documentation and instructions must be adhered to when refitting the camshafts - there are many detail differences on the way the jig is used and the correct camshaft support fixtures and gear tooth alignment clamp must be used for each specific engine. For example, bolted-on camshaft supports may have to be removed or repositioned depending on the specific engine application's instructions.

Components

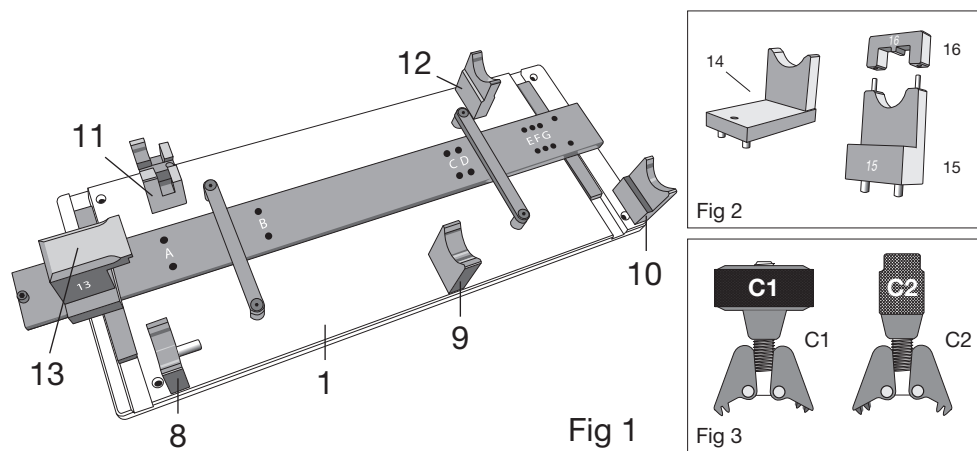

Ref No.	OEM No.	Description
1	T40094	Jig Assembly (includes parts 8, 9, 10, 11, 12 and 13.
2	T40095	Camshaft retaining clamp
C1	T40096	Gear tooth alignment clamp
C2	T40096/1	Gear tooth alignment clamp
6	T40094/1	Camshaft support
7	T40094/2	Camshaft support
14	T40094/9	Camshaft support
15	T40094/10	Camshaft support
16	T40094/11	Camshaft support locking device

Refer to Figures 1, 2, 3 and 8:

Instructions

- The camshafts may only be installed with this camshaft fitting tool set. Otherwise the axial thrust bearings in the retaining frame will be destroyed and the cylinder head must be replaced.
- Refer to manufacturer's documentation for the correct sequence of unscrewing the retaining frame bolts and nuts.
- Danger of dirt/debris or sealant residue entering lubrication system and bearings - cover open parts of engine.
- Clean sealing surfaces. They must be free of oil and grease.
- Oil the camshaft running surfaces.

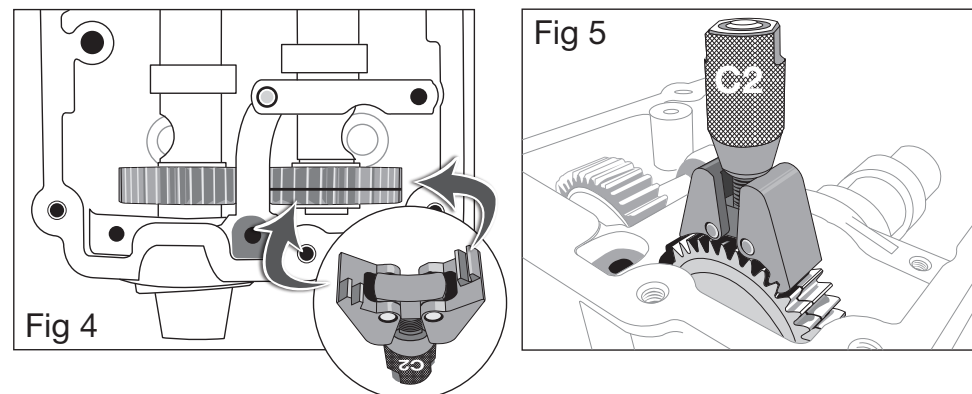

- **Gear tooth alignments clamps:** refer to Figures 4 and 5 — place **C1** or **C2** (depending on application) on the teeth of the exhaust camshaft in such a way that the two arms of the clamp engage on the two halves of the gear (one on each half, as shown in Fig 4). **The wider arm must engage in the wider gear half.** Tighten the alignment clamp using the knurled wheel so that the gear teeth are in alignment (Fig 5).

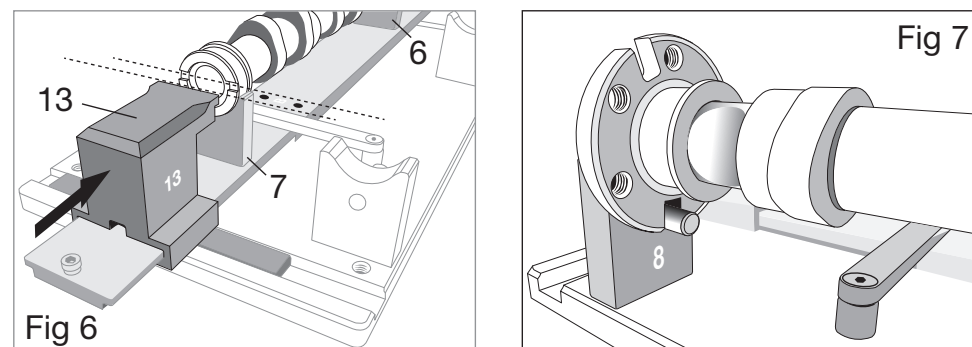

- Refer to Figures 6 and 7 for methods of locking the position of inlet and exhaust camshafts (these are representative only and will vary according to the relevant engine application).