

Our products are designed to be used correctly and with care for the purpose for which they are intended. No liability is accepted by the Tool Connection for incorrect use of any of our products, and the Tool Connection cannot be held responsible for any damage to personnel, property or equipment when using the tools. Incorrect use will also invalidate the warranty.

If applicable, the applications database and any instructional information provided has been designed to offer general guidance for a particular tool's use and while all attention is given to the accuracy of the data no project should be attempted without referring first to the manufacturer's technical documentation (workshop or instruction manual) or the use of a recognised authority such as Autodata.

It is our policy to continually improve our products and thus we reserve the right to alter specifications and components without prior notice. It is the responsibility of the user to ensure the suitability of the tools and information prior to their use.



### Guarantee

If this product fails through faulty materials or workmanship, contact our service department direct on: **+44 (0) 1926 818186**. Normal wear and tear are excluded as are consumable items and abuse.



Distributed by The Tool Connection Ltd

Kineton Road, Southam, Warwickshire CV47 0DR  
T +44 (0) 1926 815000 F +44 (0) 1926 815888  
info@toolconnection.co.uk [www.toolconnection.co.uk](http://www.toolconnection.co.uk)



# LASER<sup>®</sup>

6263

## Diesel Injector Extractor with Air Hammer & Adaptors

Instructions



REGISTERED DESIGN

This tool allows the vibration and impact delivered by an air chisel/hammer unit to be used to extract components.

Equipped with a 5/8" male thread for connection to any slide hammer adaptor with a similar internal thread.

The Tool Connection recommends the use of the Laser 6031 Air Hammer unit.

When combined with the appropriate adaptor this tool can be used to extract:

- Diesel injectors.
- Blind pivot pins such as articulated lorry fifth wheel pins.
- Small diameter bearings (under 30mm diameter).
- Dents in body work.

**We are continually developing new designs and ideas - please check website for the very latest accessories for this tool.**

Please note:

*The use of an air chisel/hammer for extraction utilises high impact and vibration levels. For this reason any component removed using this method must be properly checked and tested for functionality before being refitted.*

*The Tool Connection Limited can not be held responsible for damage caused by the use of this tool.*

## Components

| Ref | Description               |
|-----|---------------------------|
| A   | Handle                    |
| B   | Impact Boss               |
| C   | Lock Nut (mass to handle) |
| D   | Extractor Shaft           |
| E   | Lock Nut                  |
| F   | Impact Punch              |



## Preparation and Precautions

- **All lock nuts must be kept tight when in use.**
- Ensure gloves, safety glasses and ear defenders are used during the extractions process.

## Instructions for Use (Extraction)

- Check the handle and lock nut (C) are tight.
- Fit appropriate adaptor and tighten lock nut (E).
- Connect to component to be removed and tighten.
- Insert the Impact Punch (F) into the Air Hammer and ensure it is locked in place.
- Set air hammer to a low setting where possible
- Insert Impact punch fully into the impact boss.
- Operate the air hammer for 5 second bursts starting at a low setting.
- Increase the impact and vibration level as required.
- Once the component has started to move ease off on the physical upward pressure being applied to ensure the component and extractor do not suddenly fly out.

**ALWAYS HOLD THE AIR HAMMER AND EXTRACTOR COMBINATION WITH BOTH HANDS.  
DO NOT USE ANY TRIGGER LOCK FACILITY.  
NEVER PULL TOWARD THE FACE.**

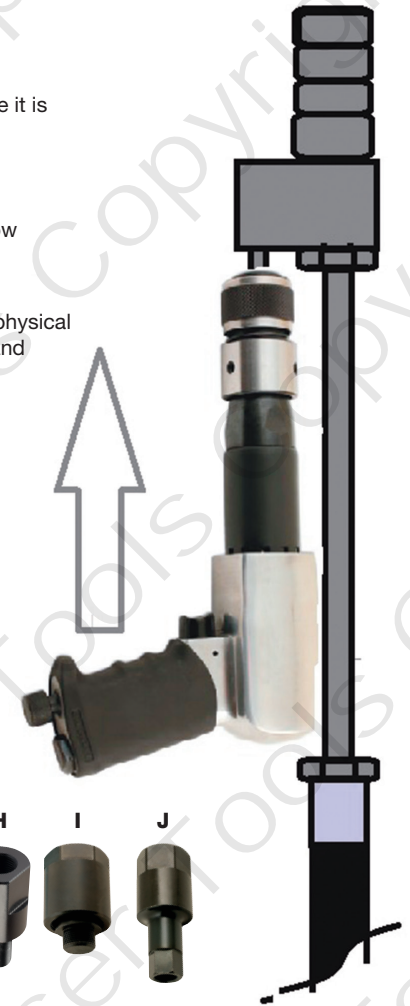

Adaptors included in this kit are:

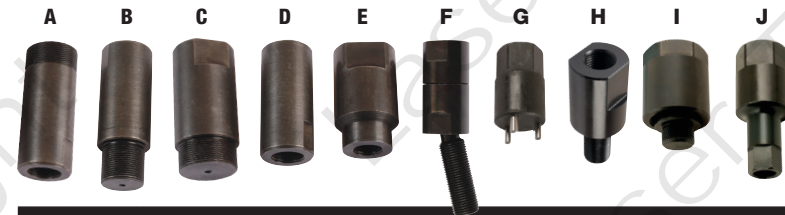

| Ref | Part No | Thread    | Description  |
|-----|---------|-----------|--|
| A   | 6118    | M25       | Siemens injectors with M25 thread  |
| B   | 6119    | M20       | Denso injectors with M20 thread (Nissan etc)   |
| C   | 6120    | M27       | Siemens injectors with M27 thread  |
| D   | 6121    | M12       | M12 internal thread to fit older style injectors equipped with M12 high pressure pipe union on the top of the injector |
| E   | 6122    | M14       | Internal for Delphi  |
| F   | 6123    | Universal | Off line action with 15° angle 30° swing   |
| G   | 6231    |           | Valve seat remover   |
| H   | 6255    | M16       | Denso adaptor  |
| I   | 5128    |           | Dual connector adaptor - Bosch   |
| J   | 4761    |           | Bosch Injector Dismantling Tool  |