

LASER[®]

6182

Shock Absorber Tool Kit 14pc

Instructions

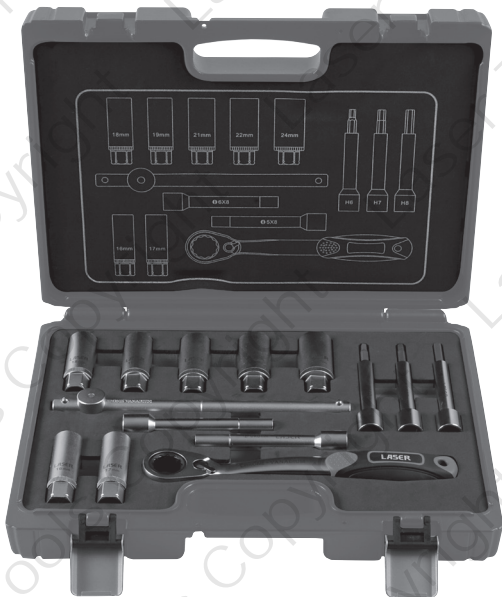

Shock Absorber Tool Kit

Description:

Designed to enable the dismantling of the top mounts used on the most common shock absorbers.

Kit includes:

- 7 x Go Thru' deep sockets sized to fit the most common shock absorber top nuts including: 16mm, 17mm, 18mm, 19mm, 21mm, 22mm, 24mm x 75mm long.
- 1 x Go Thru' ratchet 21mm Hex drive.
- 3 x 1/2"D Hex bits including: 6mm, 7mm, 8mm used to hold the shock absorber shaft.
- 2 x slot bit sockets including: 5mm x 8mm and 6mm x 8mm 1/2"D, used to hold the shock absorber shaft.

Examples of use include:

- 6mm Hex and 8mm Hex used on Mercedes-Benz with 19mm socket.
- 8mm Hex for BMW combined with appropriate socket.
- 7mm for GM/Vauxhall combined with appropriate socket.
- Slot bit socket combined with 17mm socket used on Volkswagen and Audi models.

Applications are for guidance only.

Instructions

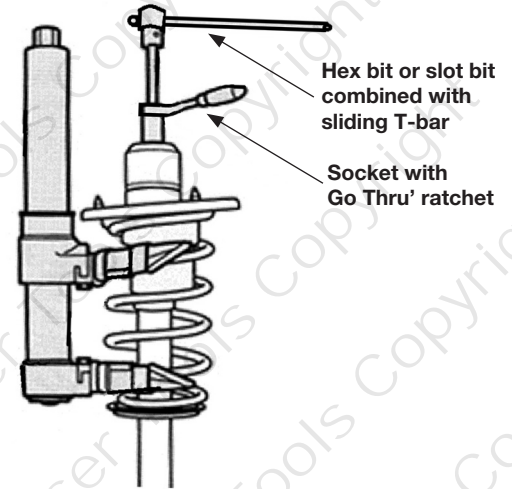

WARNING: ALWAYS USE APPROPRIATE SPRING COMPRESSOR BEFORE REMOVING TOP FIXINGS.

Our products are designed to be used correctly and with care for the purpose for which they are intended. No liability is accepted by the Tool Connection for incorrect use of any of our products, and the Tool Connection cannot be held responsible for any damage to personnel, property or equipment when using the tools. Incorrect use will also invalidate the warranty.

If applicable, the applications database and any instructional information provided has been designed to offer general guidance for a particular tool's use and while all attention is given to the accuracy of the data no project should be attempted without referring first to the manufacturer's technical documentation (workshop or instruction manual) or the use of a recognised authority such as Autodata.

It is our policy to continually improve our products and thus we reserve the right to alter specifications and components without prior notice. It is the responsibility of the user to ensure the suitability of the tools and information prior to their use.

Guarantee

If this product fails through faulty materials or workmanship, contact our service department direct on: **+44 (0) 1926 818186**. Normal wear and tear are excluded as are consumable items and abuse.

 **TOOL
CONNECTION**
The Complete Connection

Distributed by The Tool Connection Ltd

Kineton Road, Southam, Warwickshire CV47 0DR
T +44 (0) 1926 815000 F +44 (0) 1926 815888
info@toolconnection.co.uk www.toolconnection.co.uk

